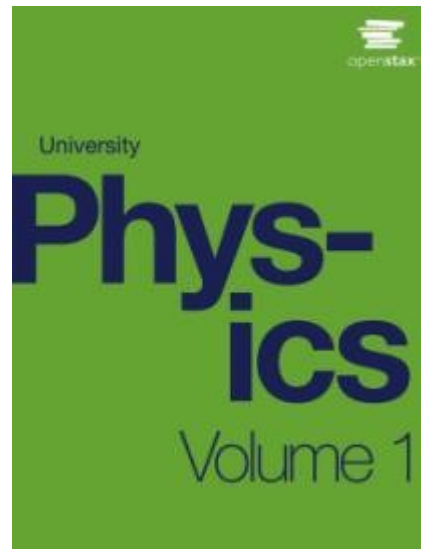


# UNIVERSITY PHYSICS

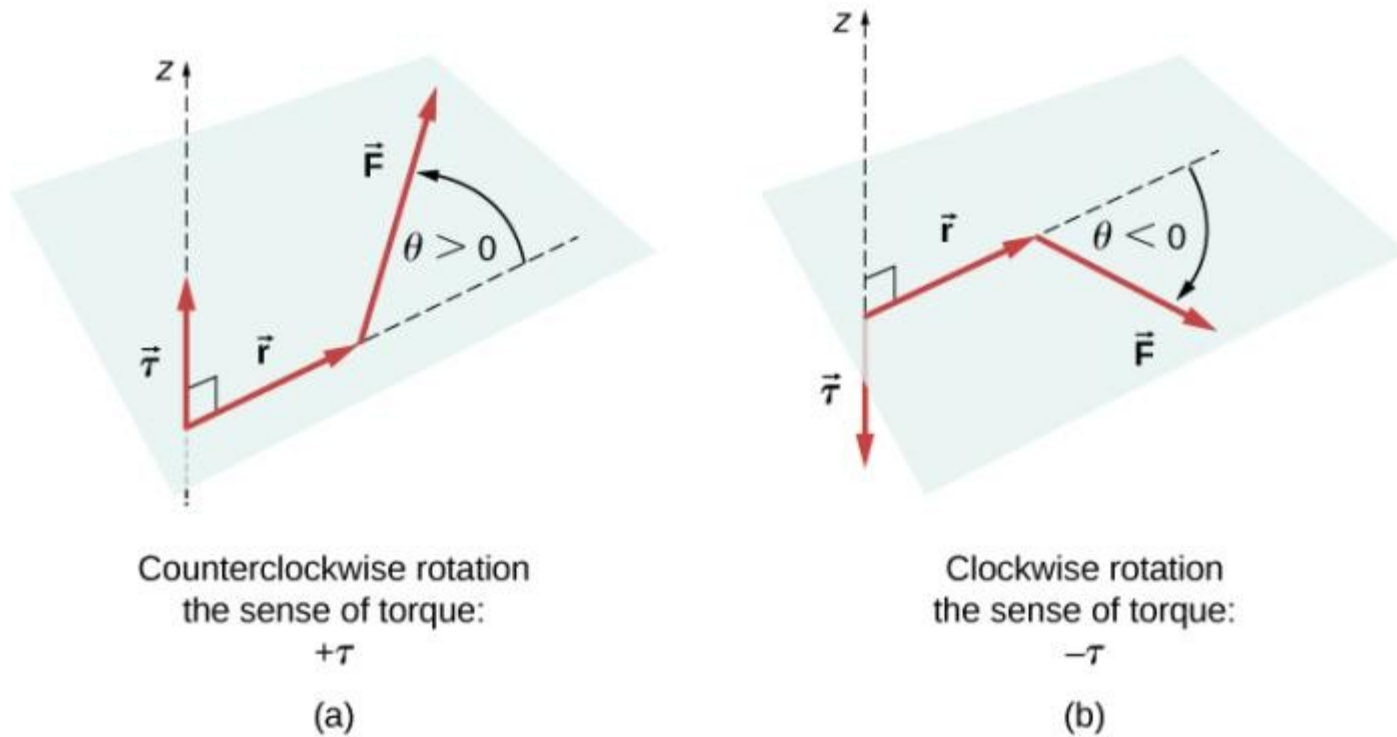
## Chapter 12 STATIC EQUILIBRIUM AND ELASTICITY

PowerPoint Image Slideshow



**Equilibrium**

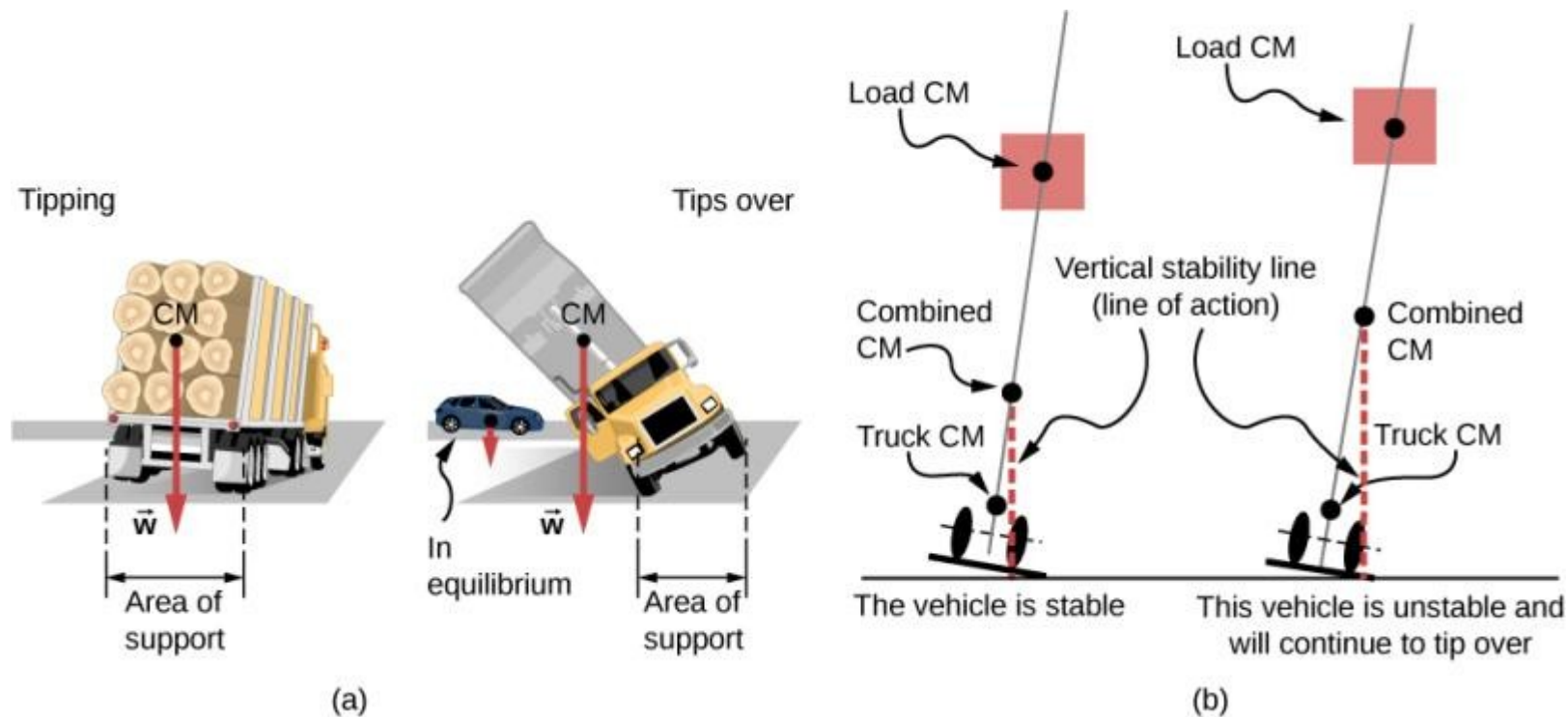
# FIGURE 12.2



Torque of a force:

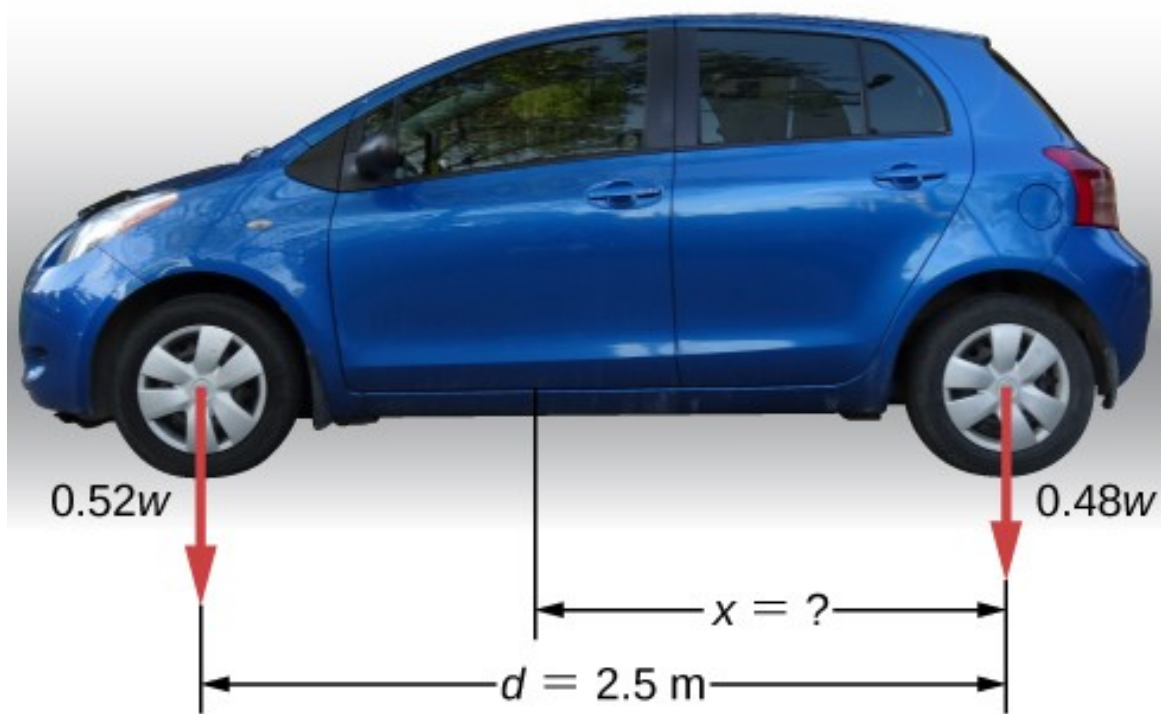
- When the torque of a force causes counterclockwise rotation about the axis of rotation, we say that its *sense* is positive, which means the torque vector is parallel to the axis of rotation.
- When torque of a force causes clockwise rotation about the axis, we say that its sense is negative, which means the torque vector is antiparallel to the axis of rotation.

# FIGURE 12.3



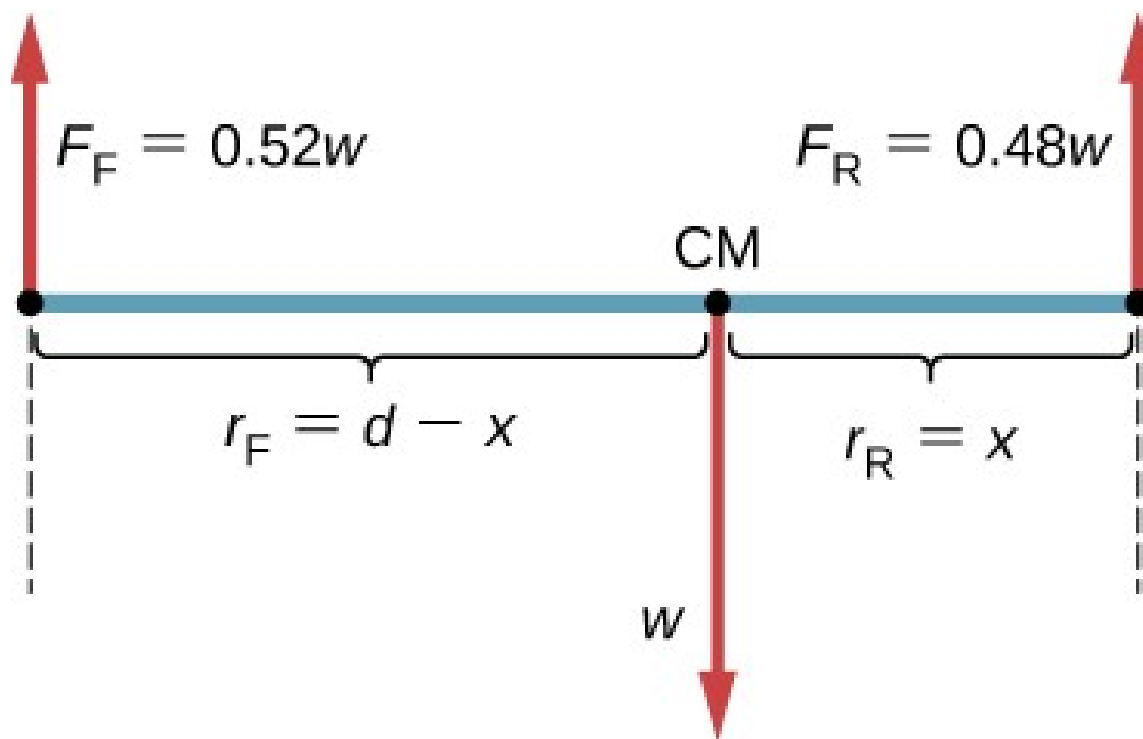
The distribution of mass affects the position of the center of mass (CM), where the weight vector is attached. If the center of gravity is within the area of support, the truck returns to its initial position after tipping [see the left panel in (b)]. But if the center of gravity lies outside the area of support, the truck turns over [see the right panel in (b)]. Both vehicles in (b) are out of equilibrium. Notice that the car in (a) is in equilibrium: The low location of its center of gravity makes it hard to tip over.

# FIGURE 12.4



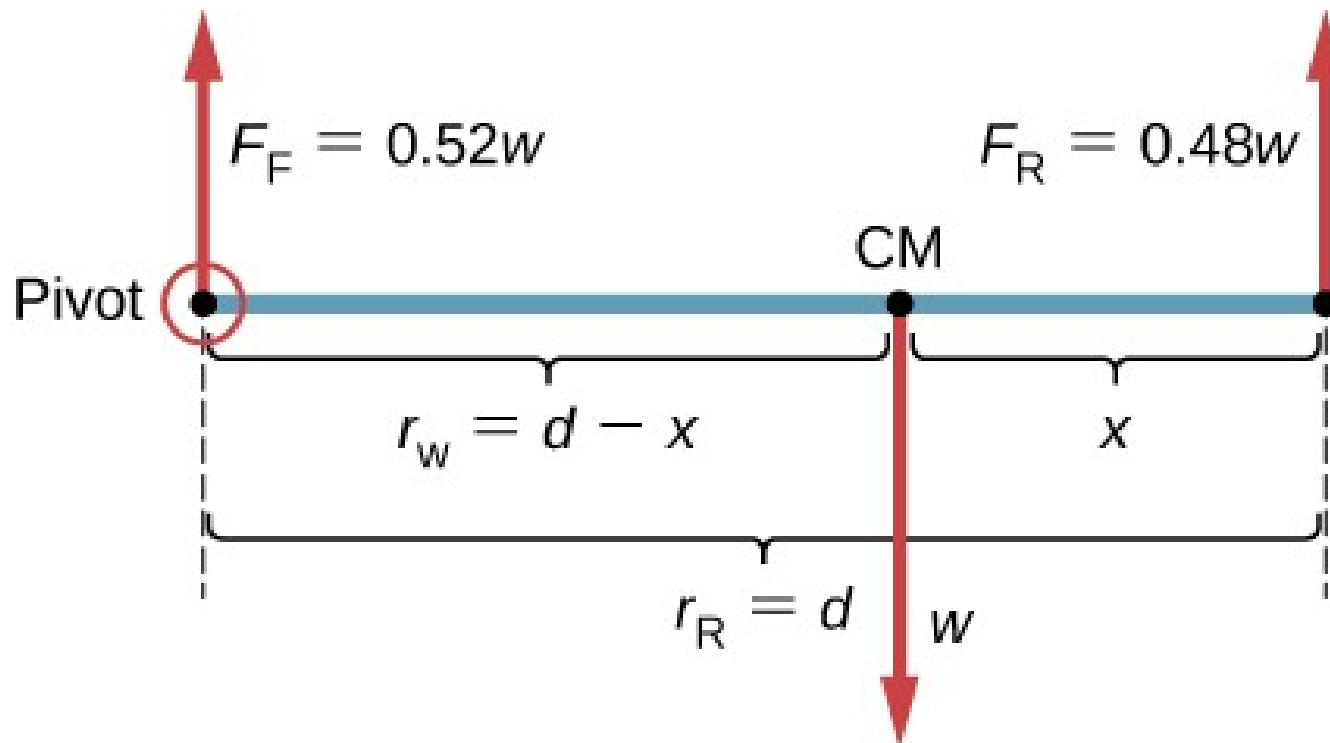
The weight distribution between the axles of a car. Where is the center of gravity located?

**FIGURE 12.5**



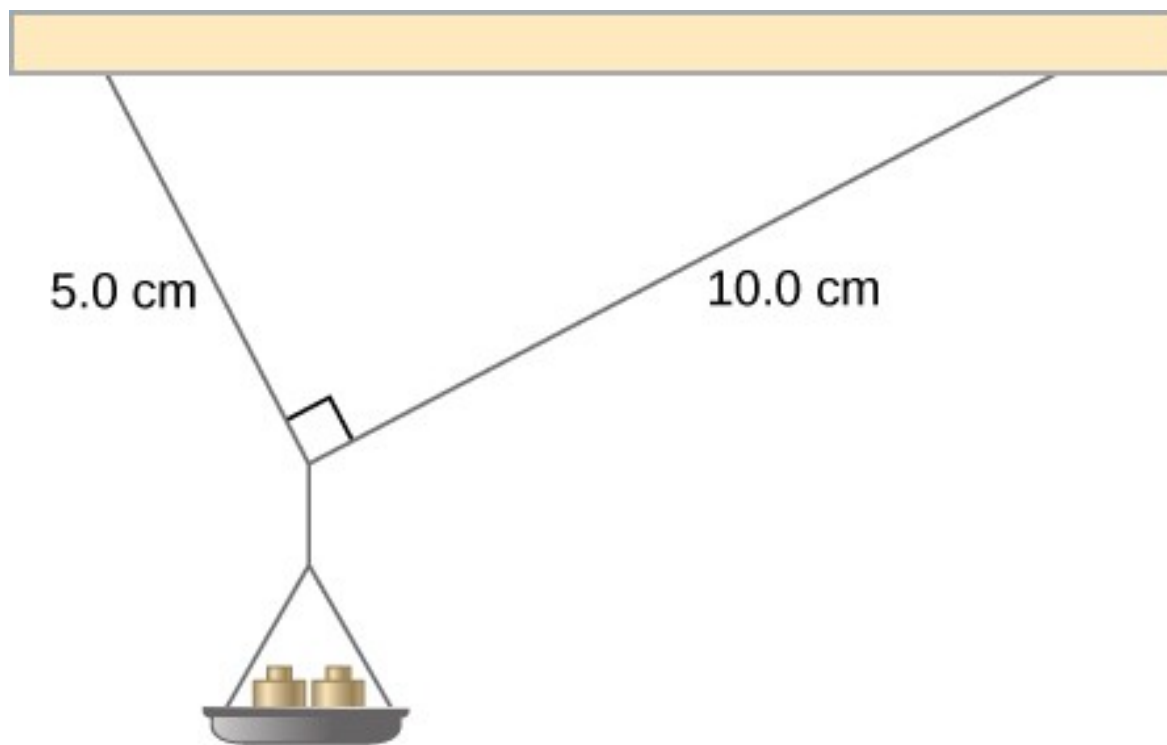
The free-body diagram for the car clearly indicates force vectors acting on the car and distances to the center of mass (CM). When CM is selected as the pivot point, these distances are lever arms of normal reaction forces. Notice that vector magnitudes and lever arms do not need to be drawn to scale, but all quantities of relevance must be clearly labeled.

**FIGURE 12.6**



The equivalent free-body diagram for the car; the pivot is clearly indicated.

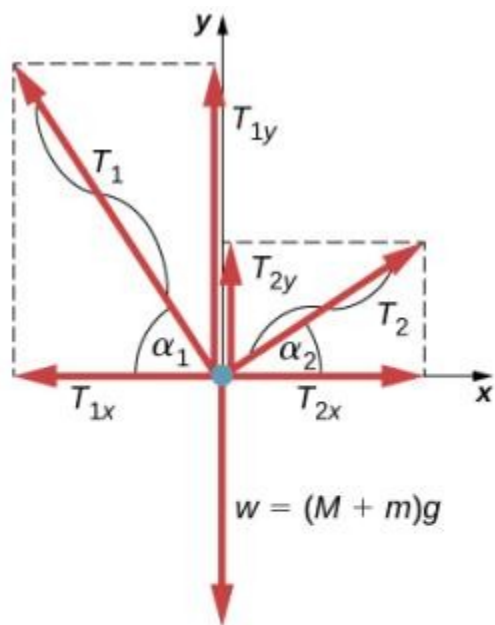
**FIGURE 12.7**



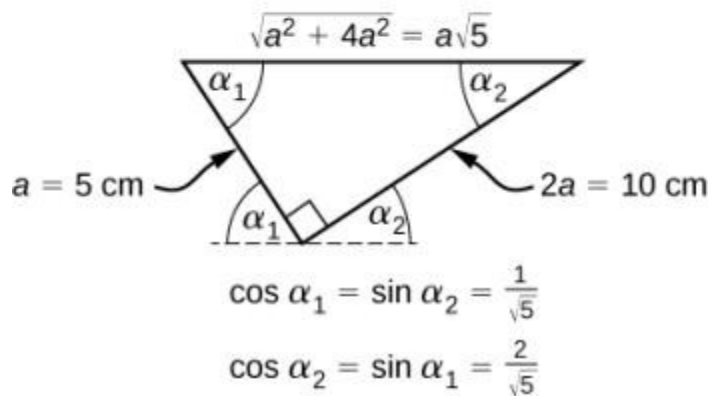
Mass is added gradually to the pan until one of the strings snaps.



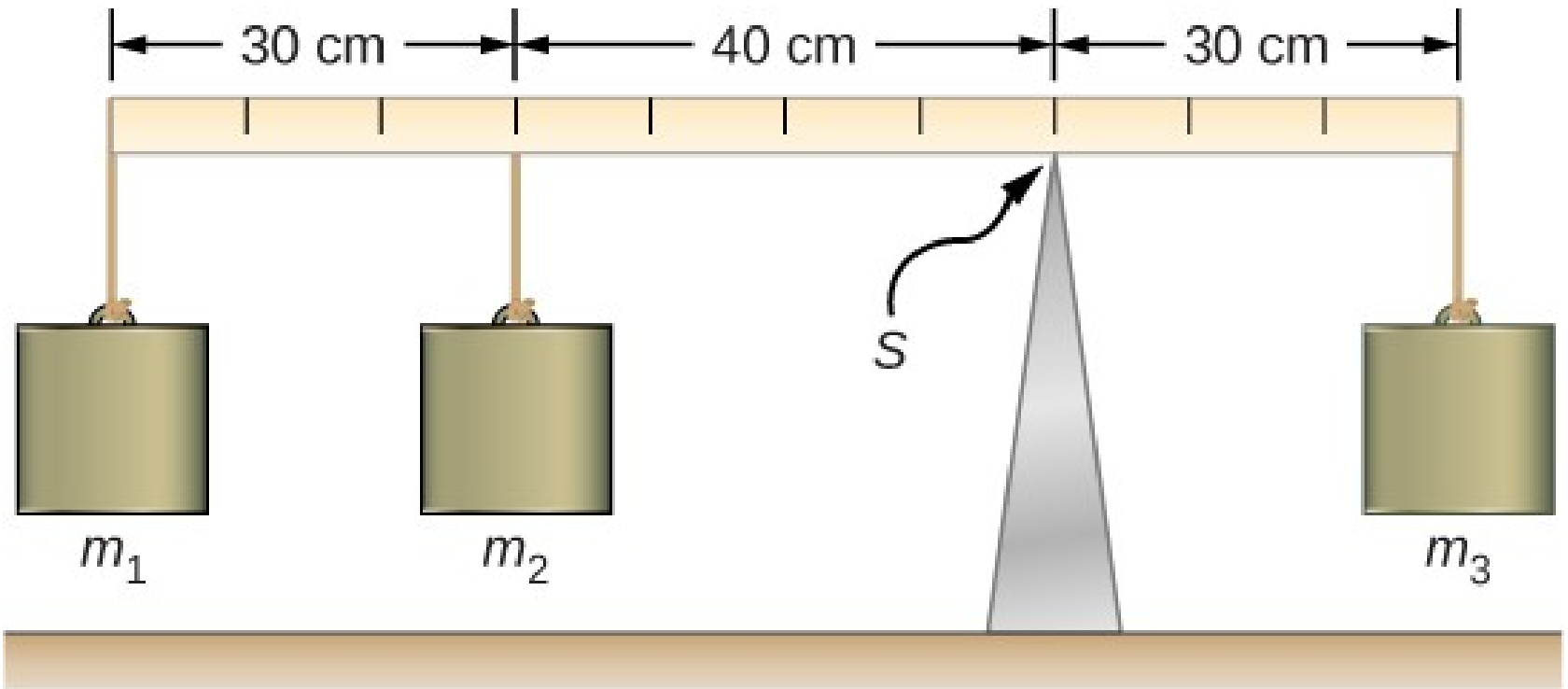
# FIGURE 12.8



Free-body diagram for the knot in **Example 12.2**.

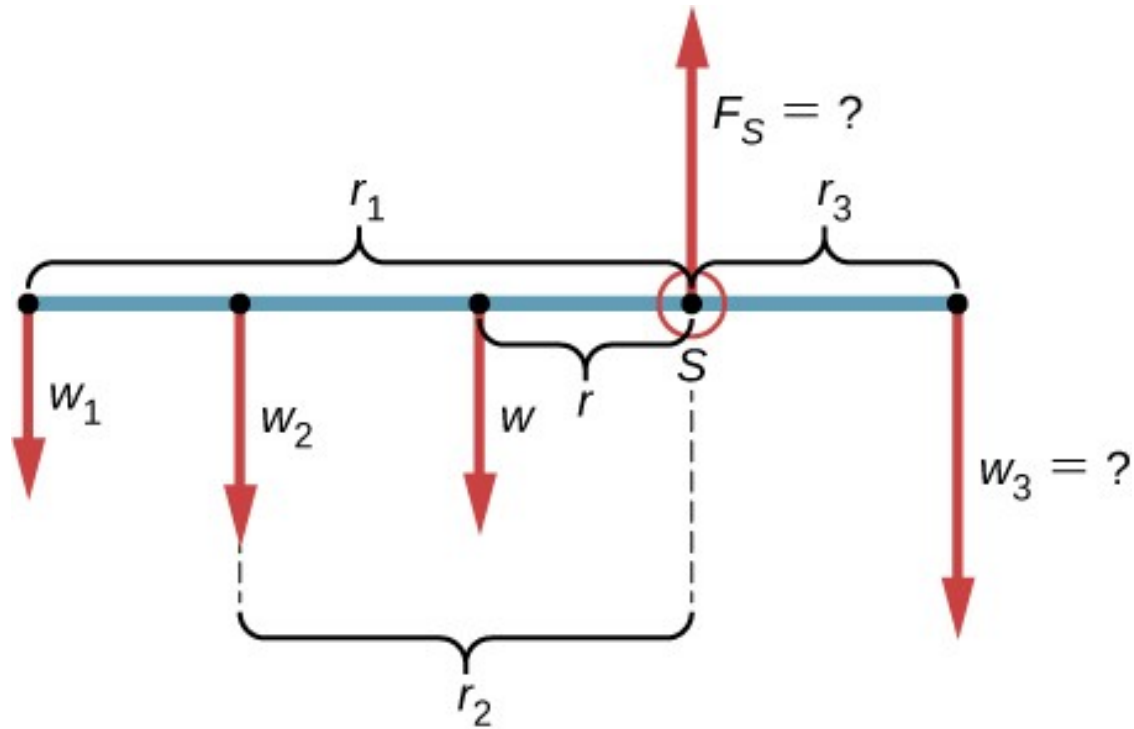


**FIGURE 12.9**



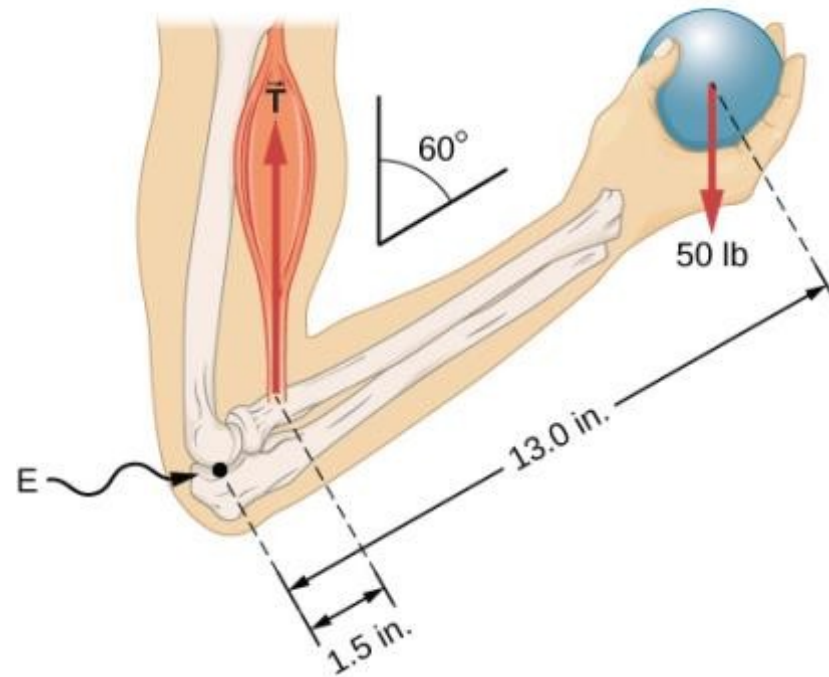
In a torque balance, a horizontal beam is supported at a fulcrum (indicated by S) and masses are attached to both sides of the fulcrum. The system is in static equilibrium when the beam does not rotate. It is balanced when the beam remains level.

# FIGURE 12.10



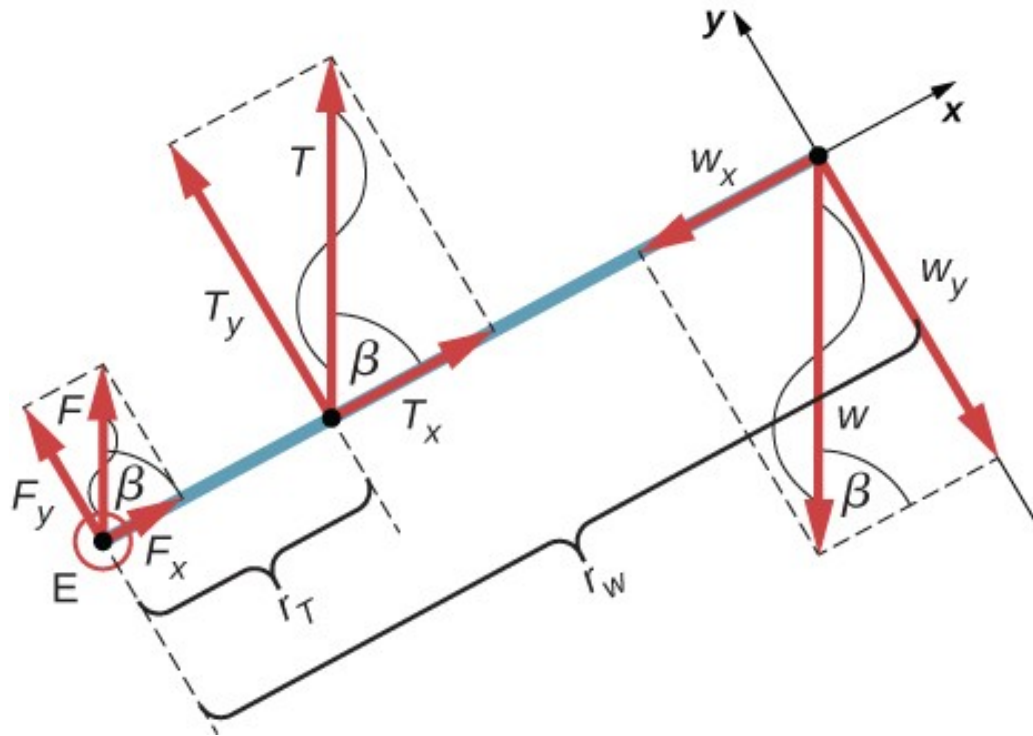
Free-body diagram for the meter stick. The pivot is chosen at the support point S.

## FIGURE 12.11



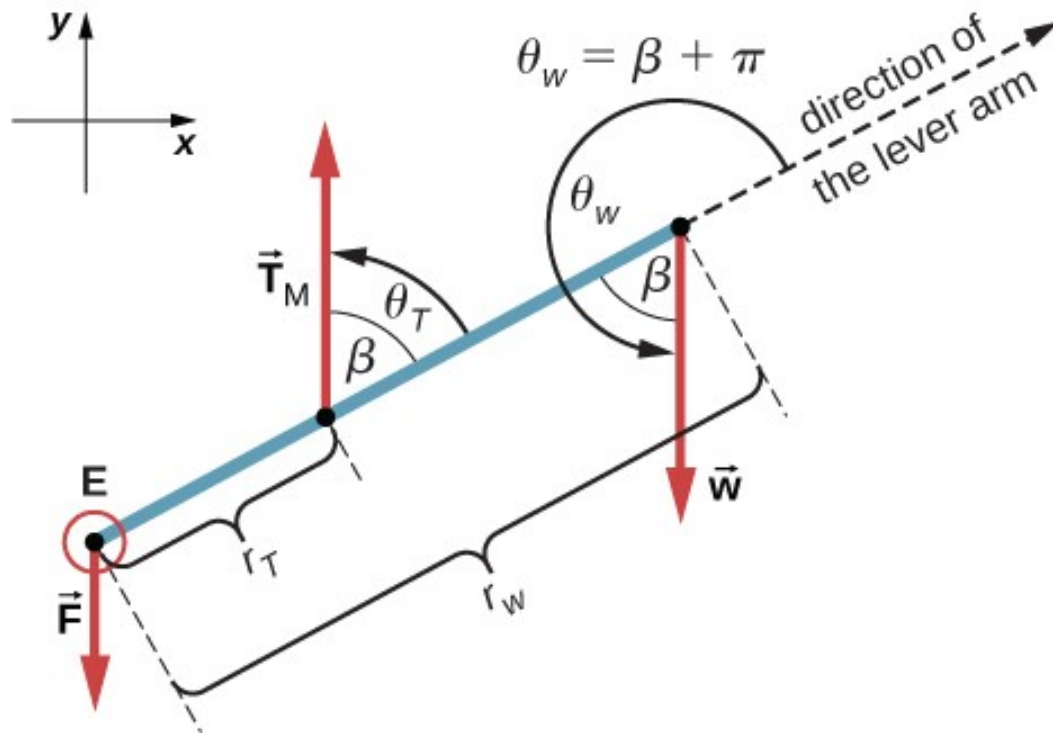
The forearm is rotated around the elbow ( $E$ ) by a contraction of the biceps muscle, which causes tension .

# FIGURE 12.12



Free-body diagram for the forearm: The pivot is located at point  $E$  (elbow).

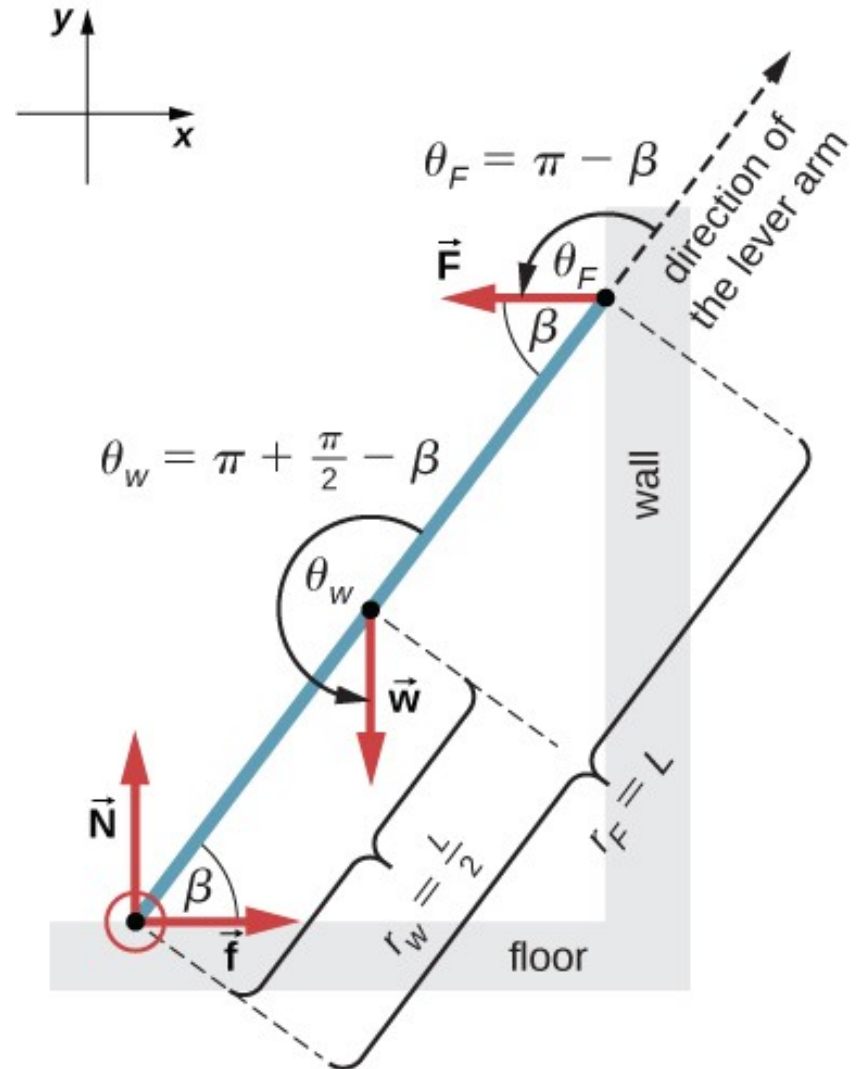
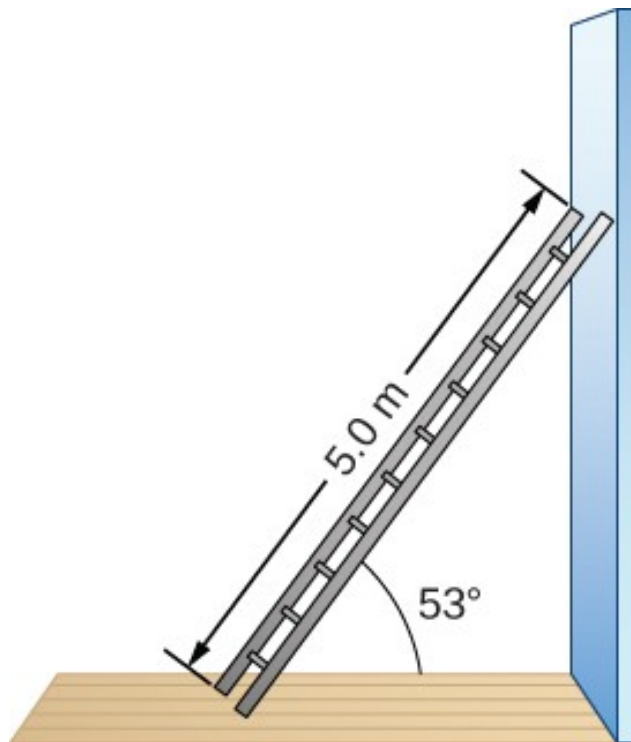
# FIGURE 12.13



Free-body diagram for the forearm for the equivalent solution. The pivot is located at point  $E$  (elbow).

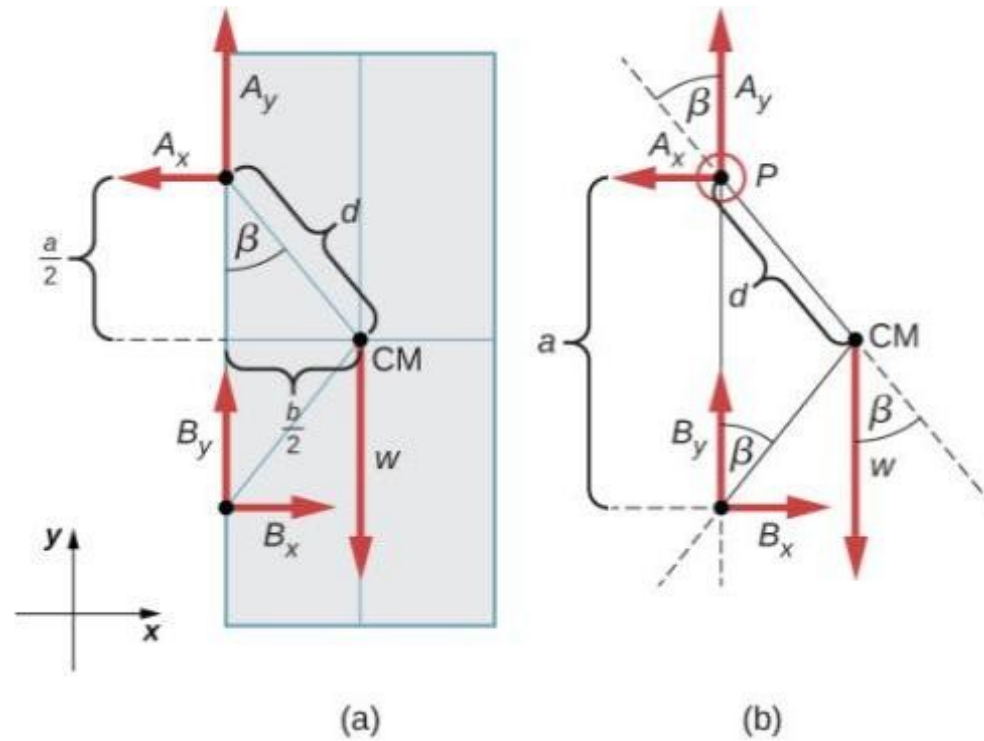
**FIGURE 12.15**

Free-body diagram for a ladder resting against a frictionless wall.



A 5.0-m-long ladder rests against a frictionless wall.

# FIGURE 12.17

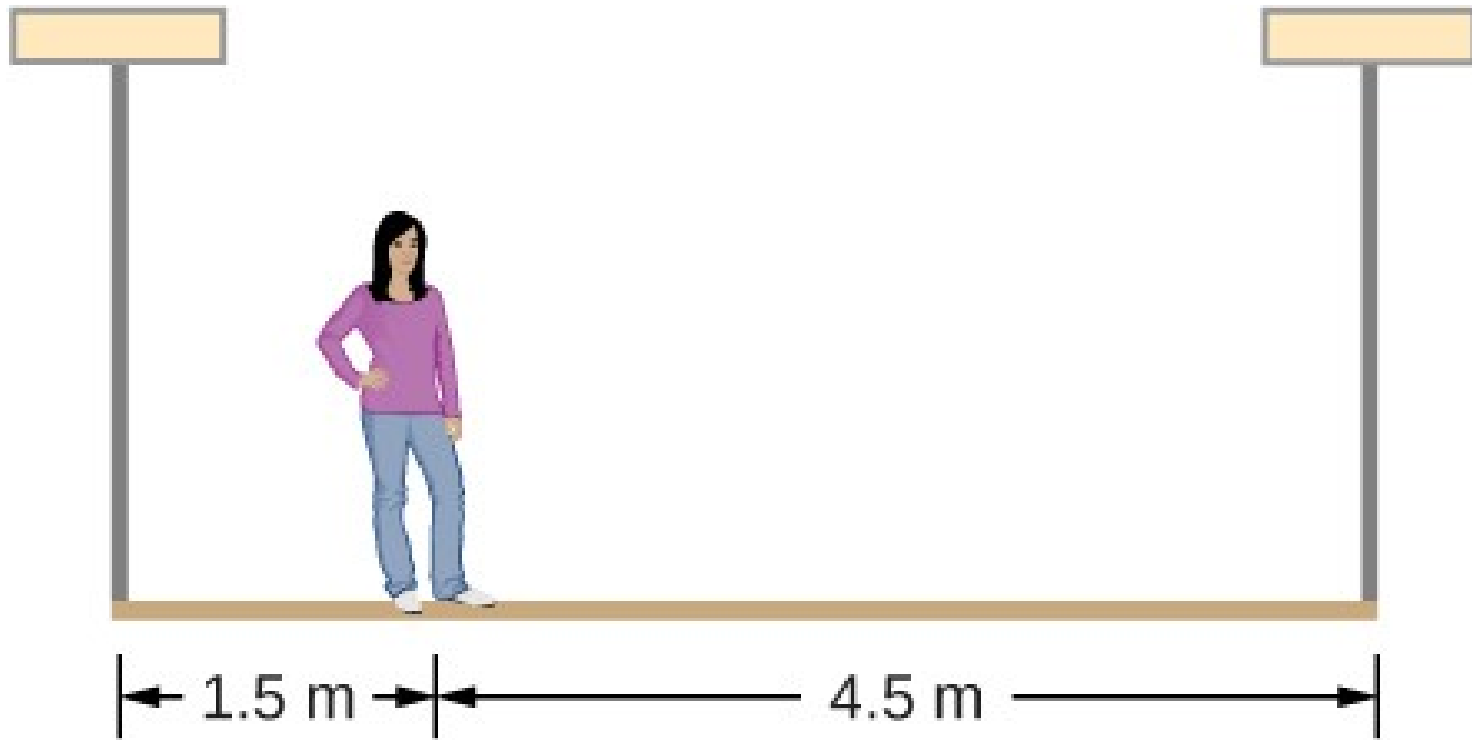


(a) Geometry and (b) free-body diagram for the door.

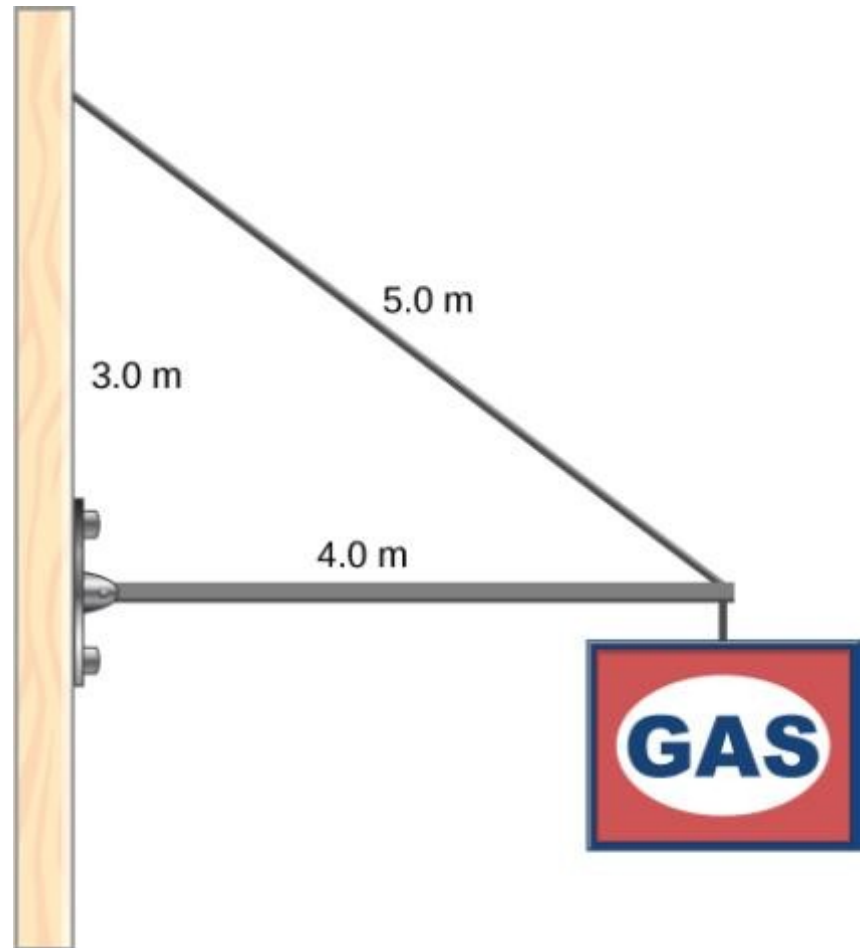
A 400-N swinging vertical door is supported by two hinges attached at points A and B.



## EXERCISE 12.7

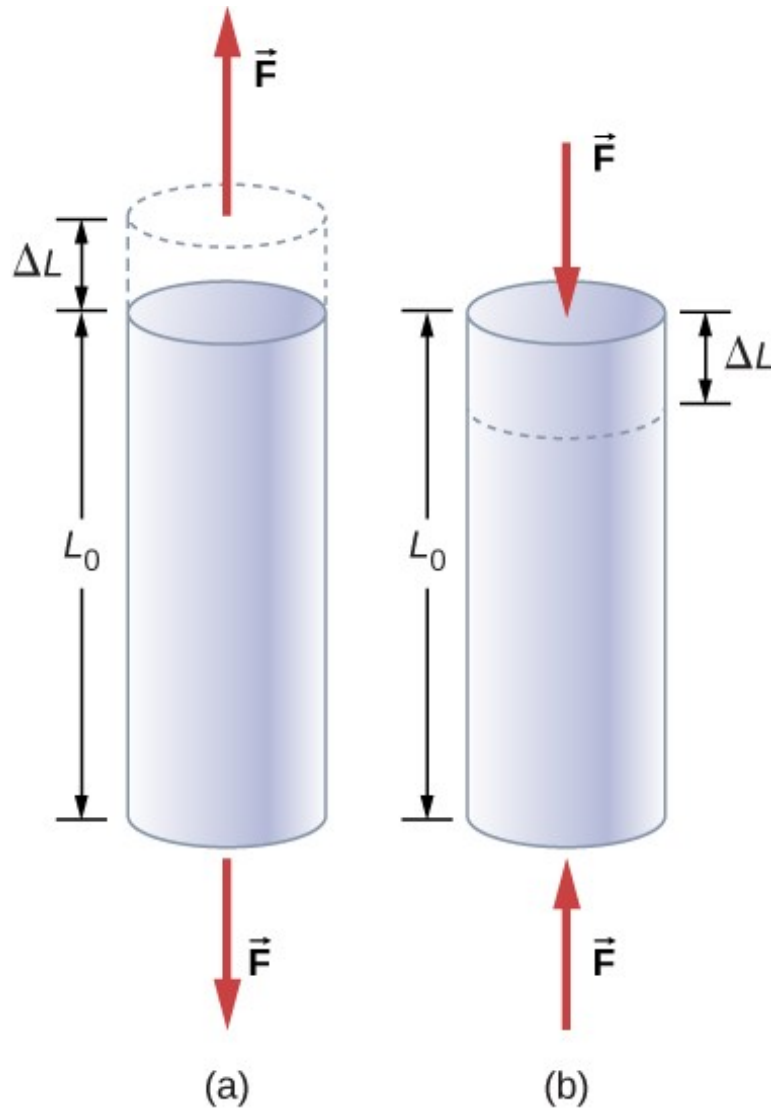


## EXERCISE 12.8



# **Tensile and compressive stress**

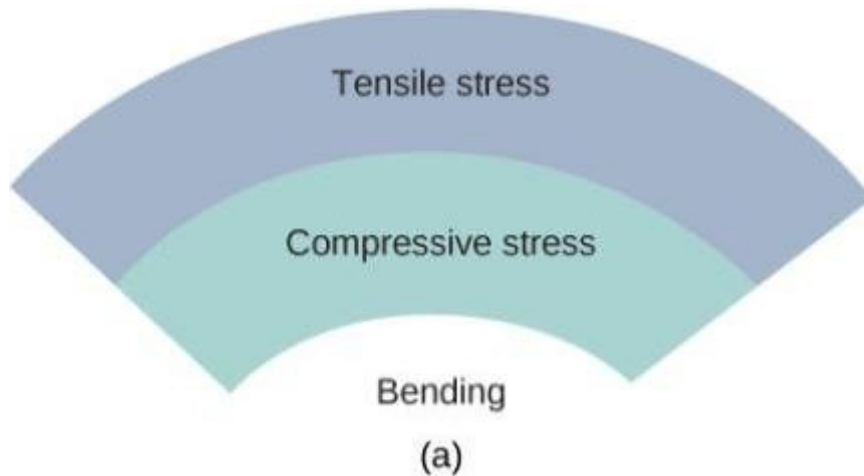
# FIGURE 12.18



When an object is in either tension or compression, the net force on it is zero, but the object deforms by changing its original length  $L_0$ .

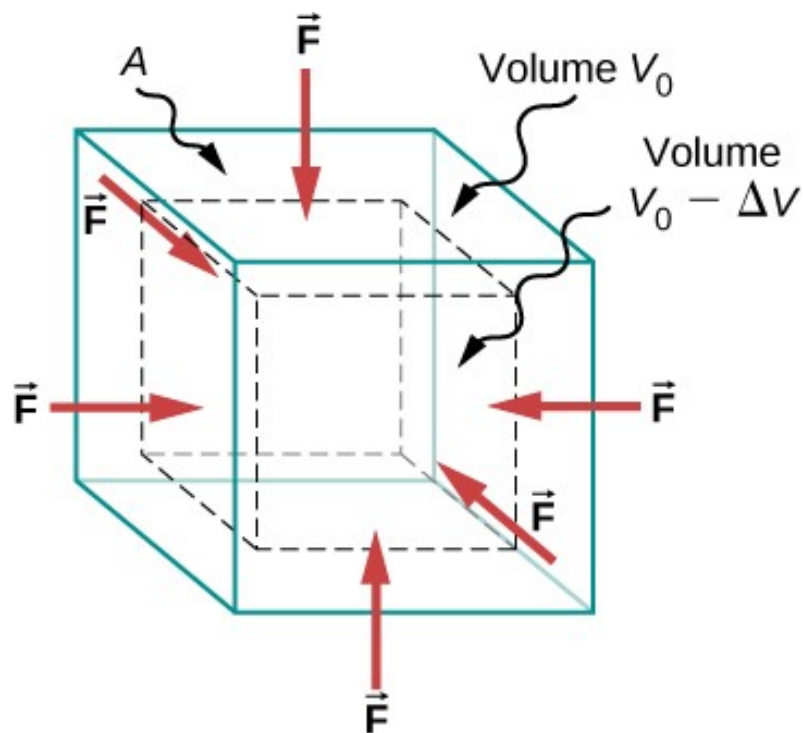
- a) Tension: The rod is elongated by  $\Delta L$ .
- b) Compression: The rod is contracted by  $\Delta L$ . In both cases, the deforming force acts along the length of the rod and perpendicular to its cross-section. In the linear range of low stress, the cross-sectional area of the rod does not change.

# FIGURE 12.20



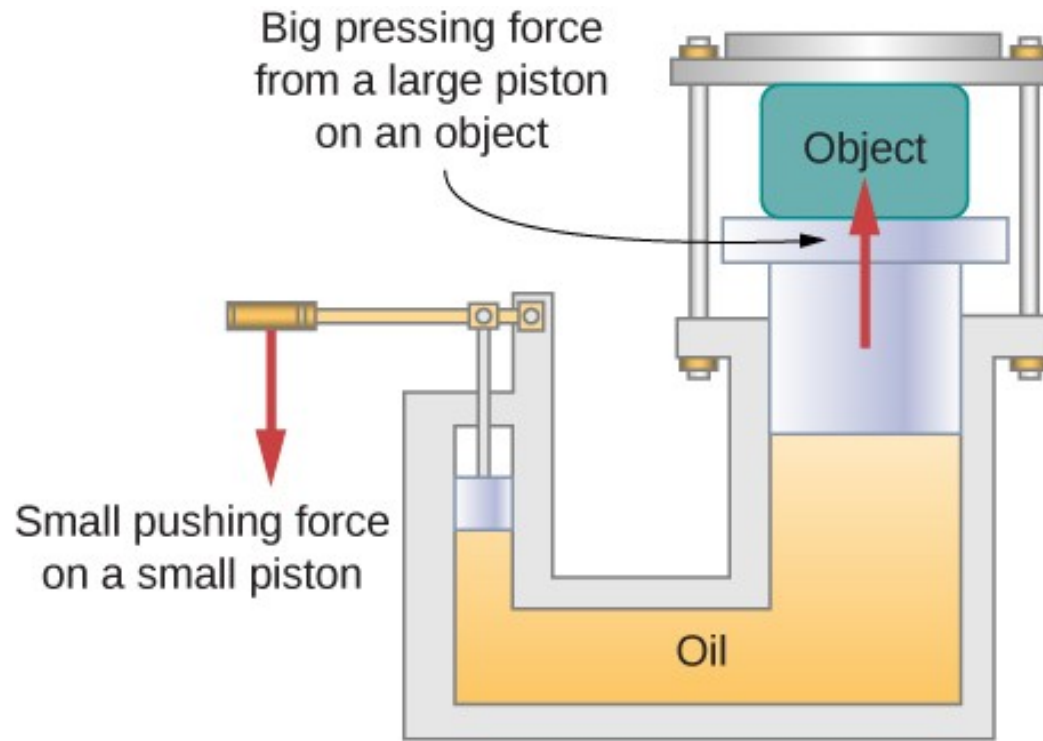
- a) An object bending downward experiences tensile stress (stretching) in the upper section and compressive stress (compressing) in the lower section.
- b) Elite weightlifters often bend iron bars temporarily during lifting, as in the 2012 Olympics competition. (credit b: modification of work by Oleksandr Kocherzhenko)

## FIGURE 12.22



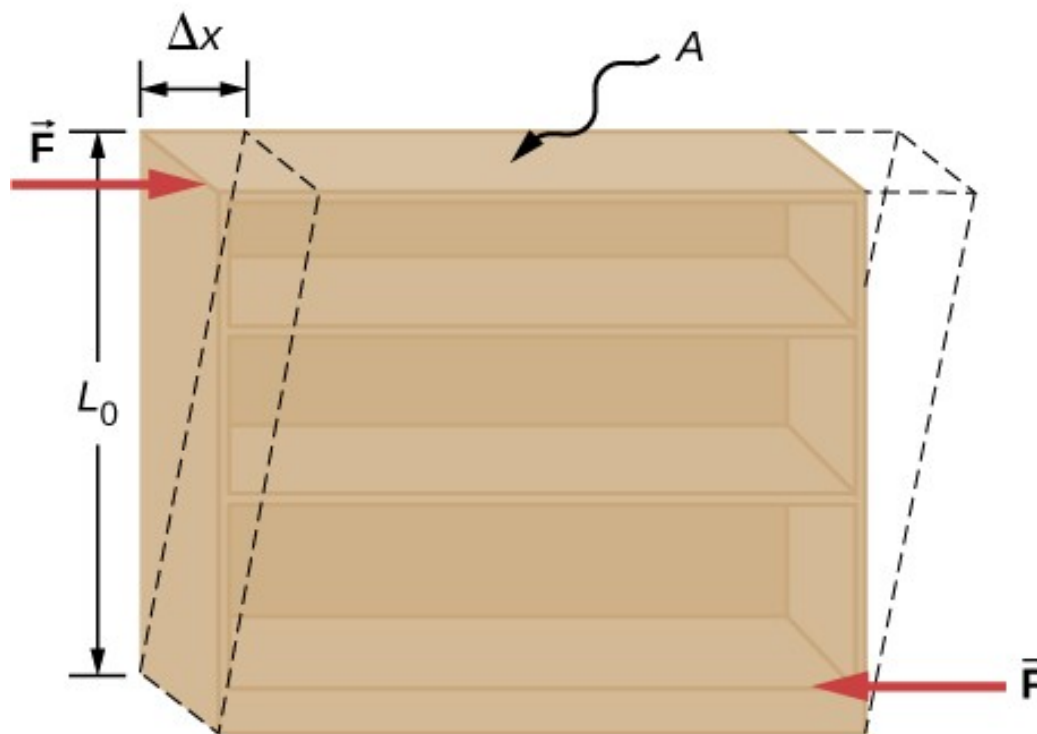
An object under increasing bulk stress always undergoes a decrease in its volume. Equal forces perpendicular to the surface act from all directions. The effect of these forces is to decrease the volume by the amount  $\Delta V$  compared to the original volume,  $V_0$ .

## FIGURE 12.23



In a hydraulic press, when a small piston is displaced downward, the pressure in the oil is transmitted throughout the oil to the large piston, causing the large piston to move upward. A small force applied to a small piston causes a large pressing force, which the large piston exerts on an object that is either lifted or squeezed. The device acts as a mechanical lever.

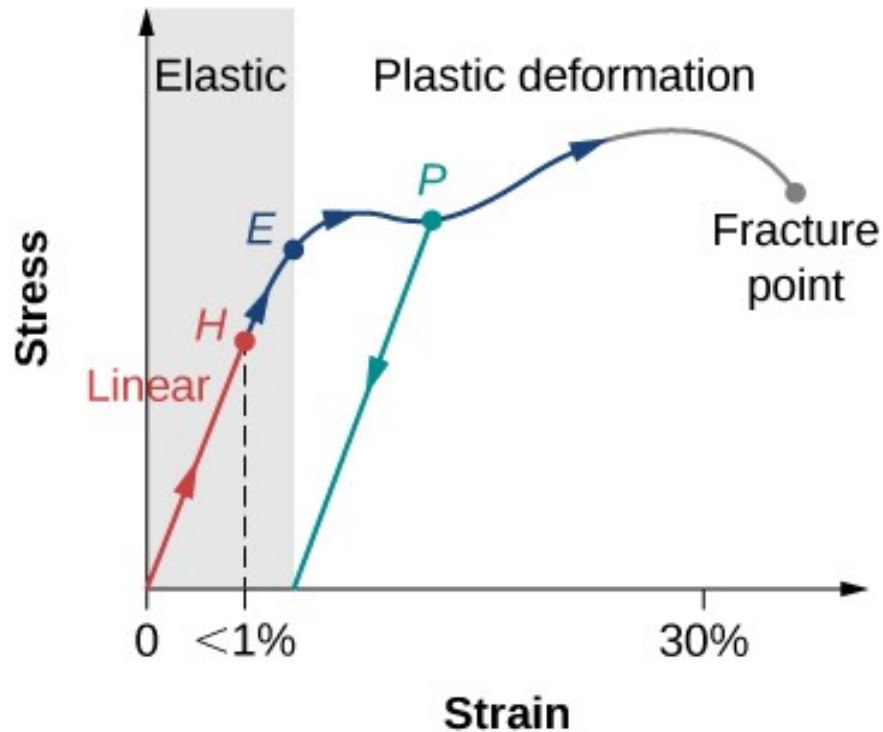
## FIGURE 12.24



An object under shear stress: Two antiparallel forces of equal magnitude are applied tangentially to opposite parallel surfaces of the object. The dashed-line contour depicts the resulting deformation. There is no change in the direction transverse to the acting forces and the transverse length  $L_0$  is unaffected. Shear deformation is characterized by a gradual shift  $\Delta x$  of layers in the direction tangent to the forces.



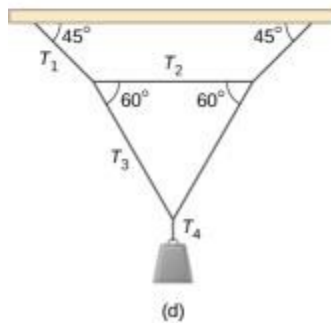
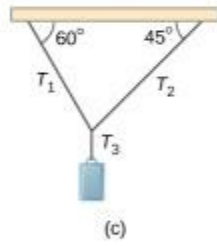
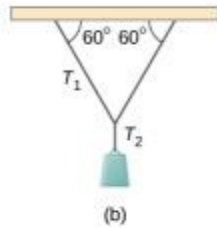
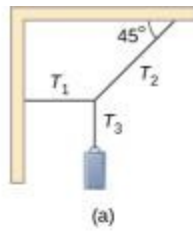
# FIGURE 12.25



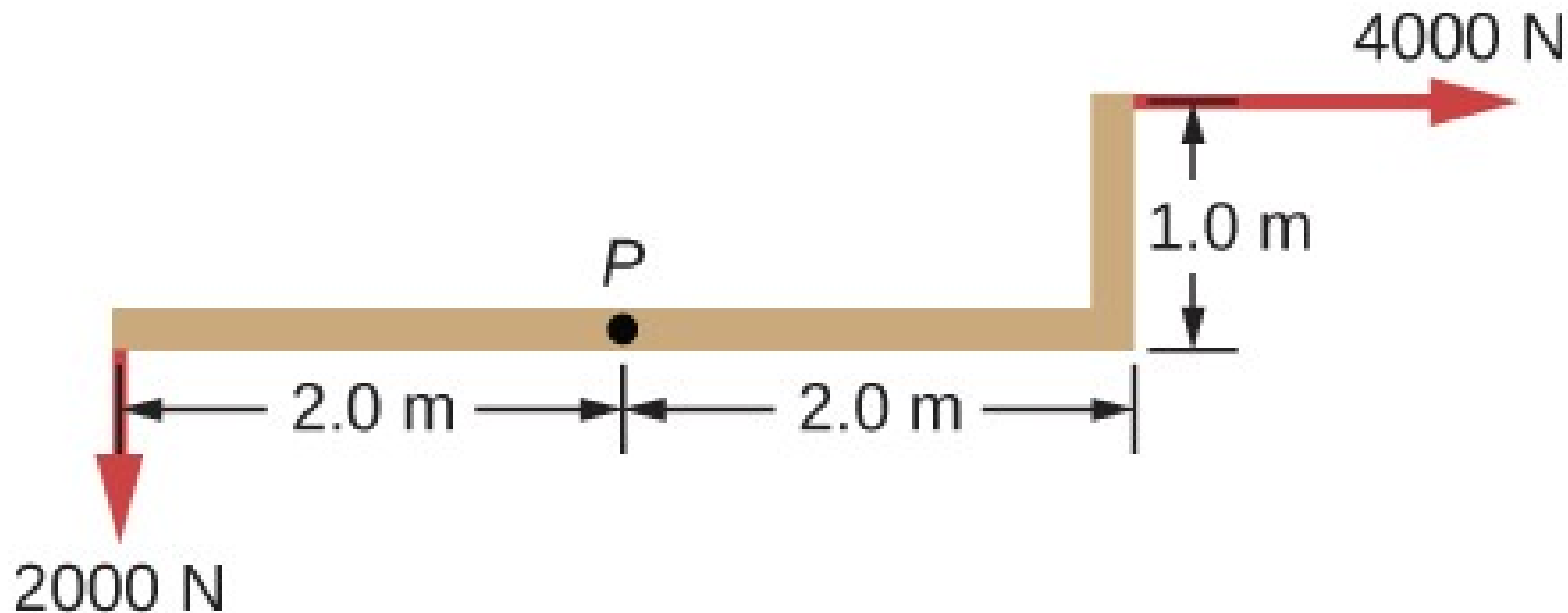
Typical stress-strain plot for a metal under a load: The graph ends at the fracture point. The arrows show the direction of changes under an ever-increasing load. Points *H* and *E* are the linearity and elasticity limits, respectively. Between points *H* and *E*, the behavior is nonlinear. The green line originating at *P* illustrates the metal's response when the load is removed. The permanent deformation has a strain value at the point where the green line intercepts the horizontal axis.

**Examples**

# EXERCISE 26

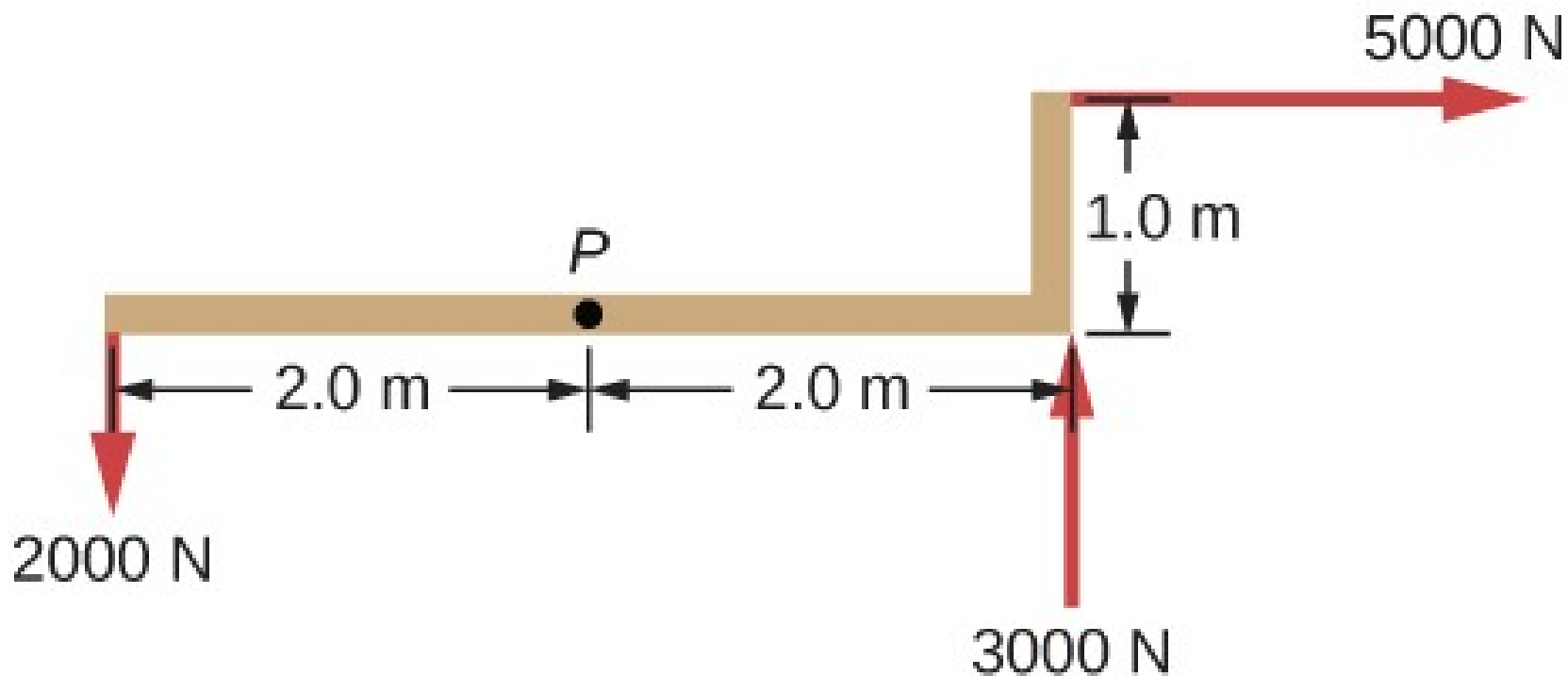


## EXERCISE 27



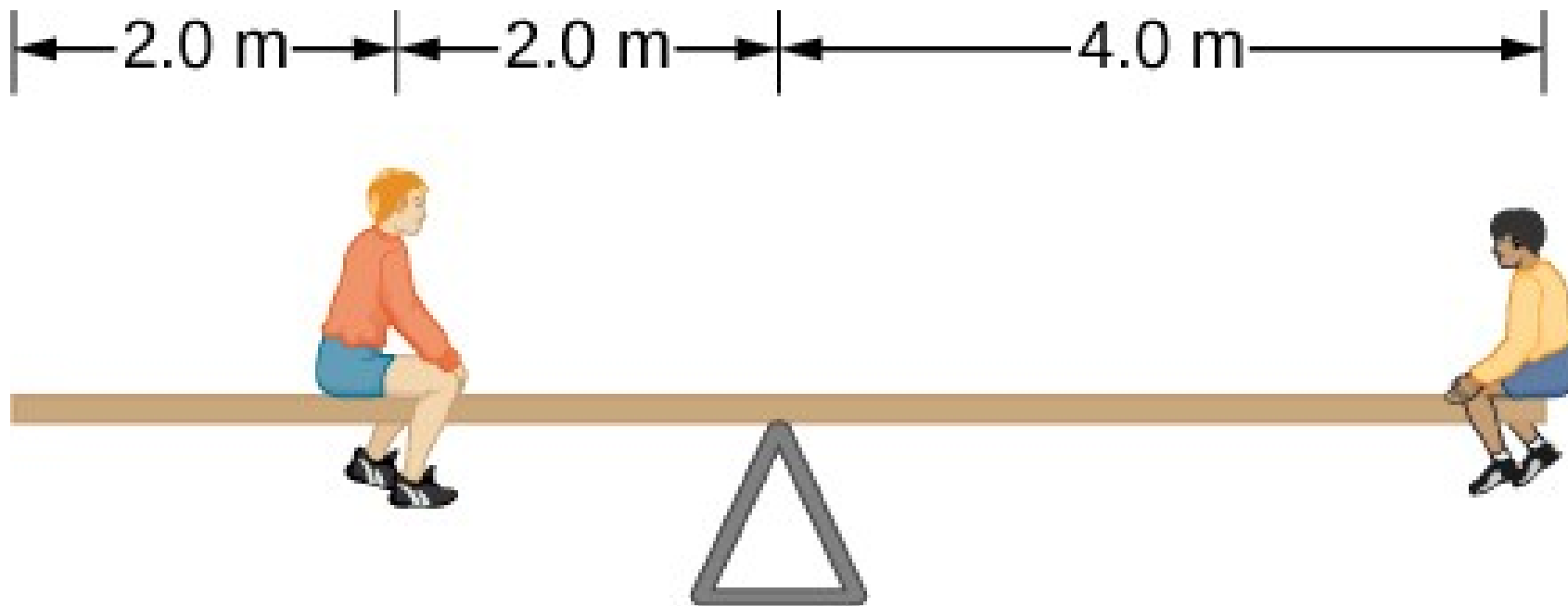
When the structure shown below is supported at point  $P$ , it is in equilibrium. Find the magnitude of force  $F$  and the force applied at  $P$ . The weight of the structure is negligible.

## EXERCISE 28



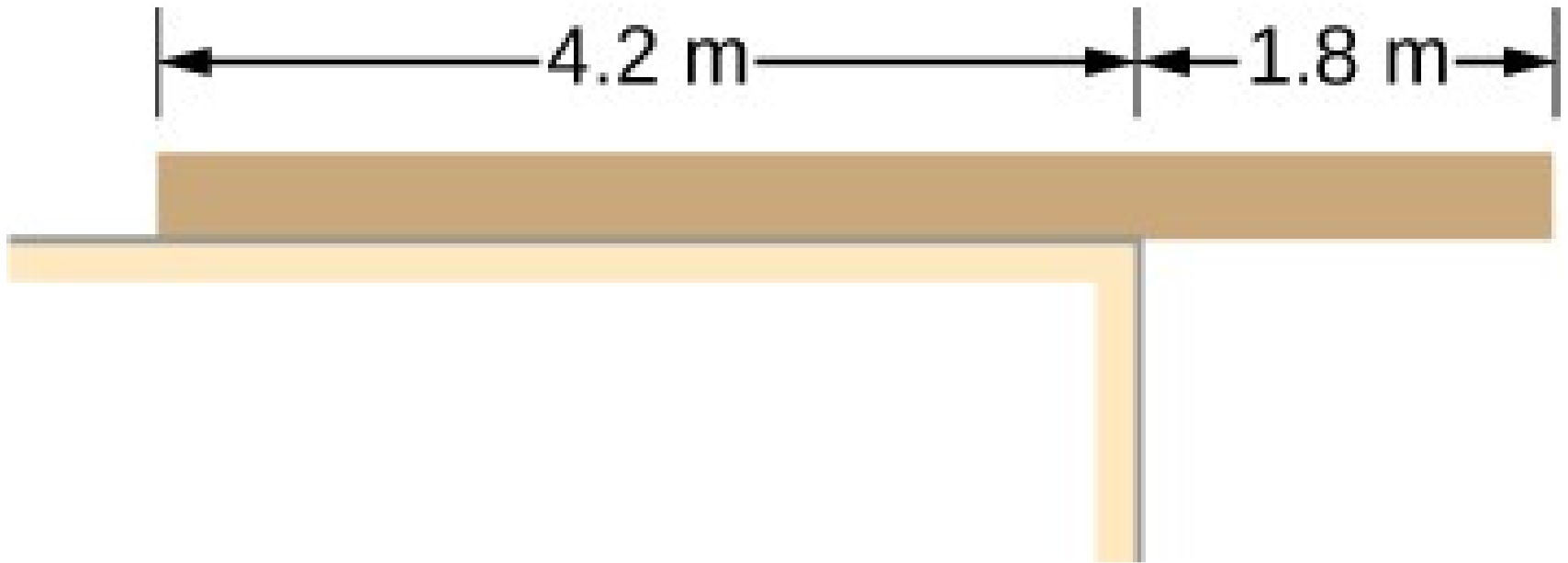
When the structure shown below is supported at point  $P$ , it is in equilibrium. Find the magnitude of force  $F$  and the force applied at  $P$ . The weight of the structure is negligible.

## EXERCISE 31



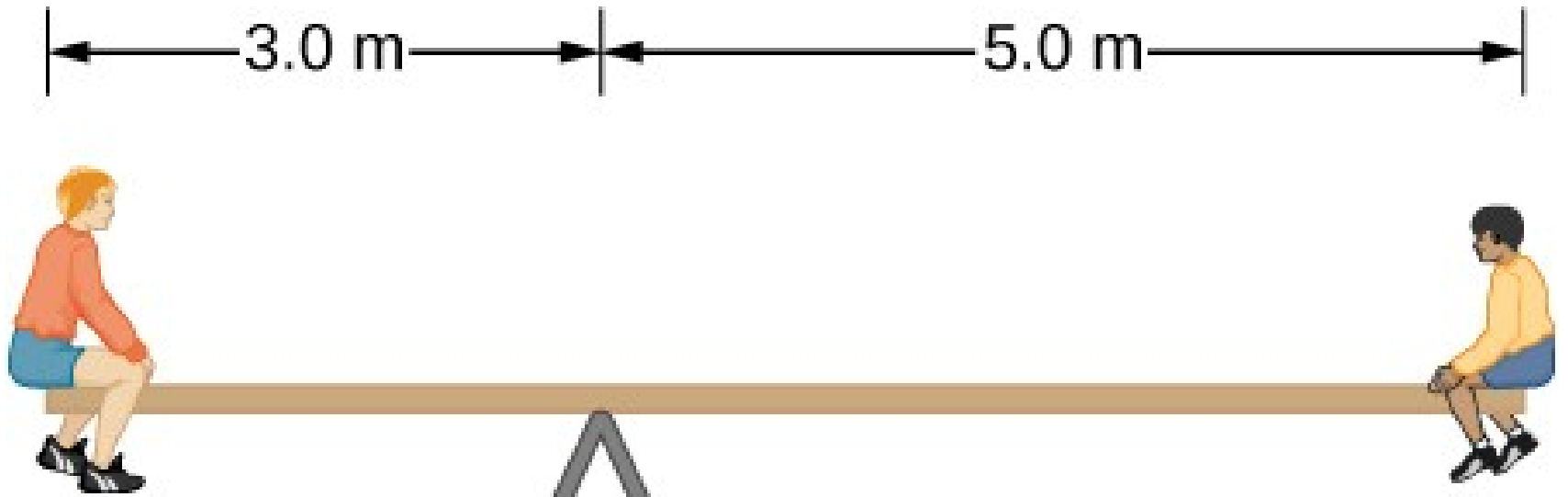
The uniform seesaw is balanced at its center of mass, as seen below. The smaller boy on the right has a mass of 40.0 kg. What is the mass of his friend?

## EXERCISE 32



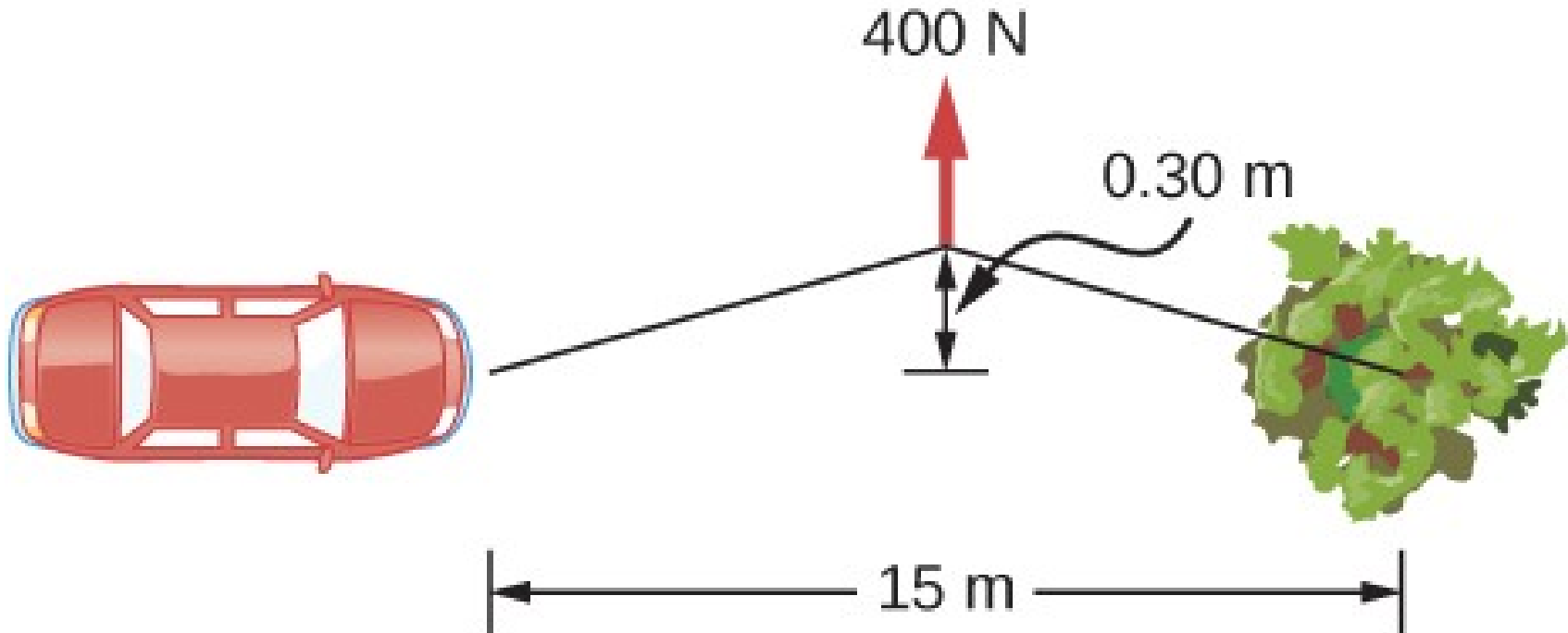
A uniform plank rests on a level surface as shown below. The plank has a mass of 30 kg and is 6.0 m long. How much mass can be placed at its right end before it tips? (*Hint:* When the board is about to tip over, it makes contact with the surface only along the edge that becomes a momentary axis of rotation.)

## EXERCISE 33





## EXERCISE 34



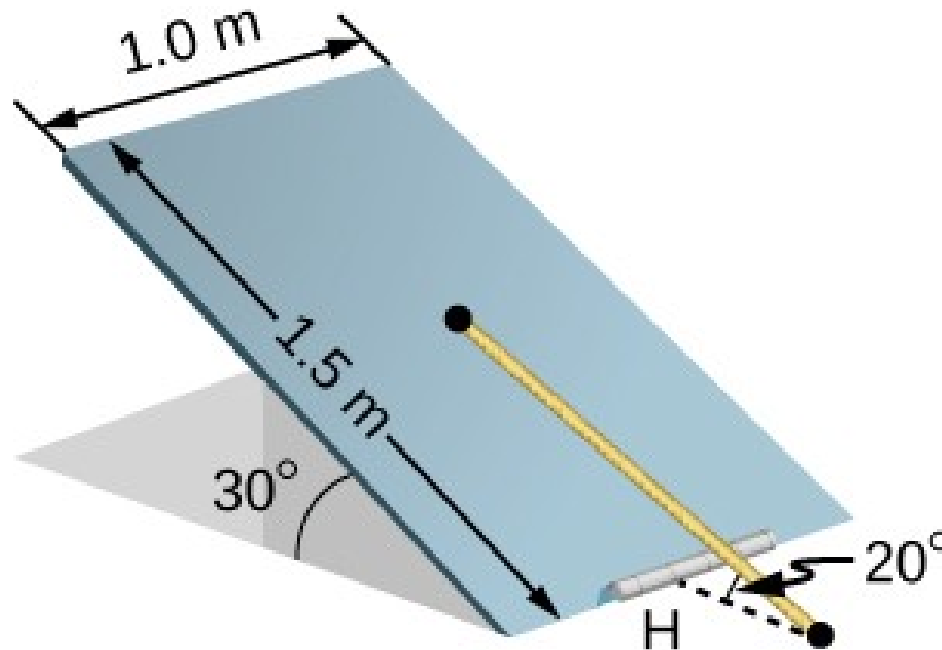
In order to get his car out of the mud, a man ties one end of a rope to the front bumper and the other end to a tree 15 m away, as shown below. He then pulls on the center of the rope with a force of 400 N, which causes its center to be displaced 0.30 m, as shown. What is the force of the rope on the car?

## EXERCISE 35



A uniform 40.0-kg scaffold of length 6.0 m is supported by two light cables, as shown below. An 80.0-kg painter stands 1.0 m from the left end of the scaffold, and his painting equipment is 1.5 m from the right end. If the tension in the left cable is twice that in the right cable, find the tensions in the cables and the mass of the equipment.

## EXERCISE 43



A uniform trapdoor shown below is 1.0 m by 1.5 m and weighs 300 N. It is supported by a single hinge (H), and by a light rope tied between the middle of the door and the floor. The door is held at the position shown, where its slab makes a  $30^\circ$  angle with the horizontal floor and the rope makes a  $20^\circ$  angle with the floor. Find the tension in the rope and the force at the hinge.



This OpenStax ancillary resource is © Rice University under a CC-BY 4.0 International license; it may be reproduced or modified but must be attributed to OpenStax, Rice University and any changes must be noted.